



02

Fresas e porta lâminas rectos
Fresas y cabezales rectos



araújo&silva
ferramentas de corte

JÁ MEDIU A SUA PRODUTIVIDADE?



A Araujo&Silva, Lda. desenvolve ferramentas especiais, proporcionando aos seus clientes as soluções mais rentáveis.



araújo&silva
ferramentas de corte

ESPECIALISTAS EM FERRAMENTA DE CORTE

www.araujosilva.pt



HW · MAN

D	B	d	Z	V	Tmax	n min · n max	Ref.
120	4	30	4	4	27	6500 - 11000	2050.101
	5	30	4	4	27	6500 - 11000	2050.102
	6	30	4	4	27	6500 - 11000	2050.103
140	4	50	4	4	32	5500 - 9500	2050.201
	5	50	4	4	32	5500 - 9500	2050.202
	6	50	4	4	32	5500 - 9500	2050.203

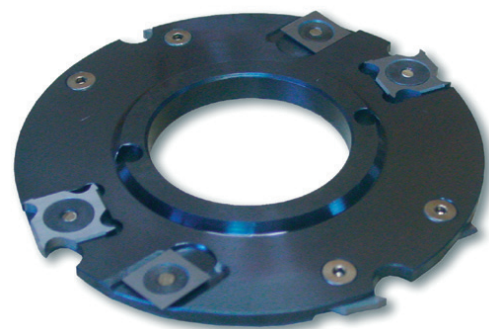

ACESSÓRIOS - Piezas de recambio

	dim.	B	Ref.
LÂMINA	18 x 18 x 1,95	4	5013.01
	18 x 18 x 2,45	5	5013.02
	18 x 18 x 2,95	6	5013.03
ANILHA DE APERTO	11,9 x 1,7	4	5110.002
	11,9 x 2,2	5/6	5110.003
VINCADOR	14 x 14 x 1,2	4/5/6	5002.03.1
ANILHA DE APERTO	9,9 x 1,6	4/5/6	5110.001
PARAFUSO	M4 x 3,2	4	5109.001
	M4 x 4,2	5/6	5109.002
CHAVE TORX	T9		5302.201

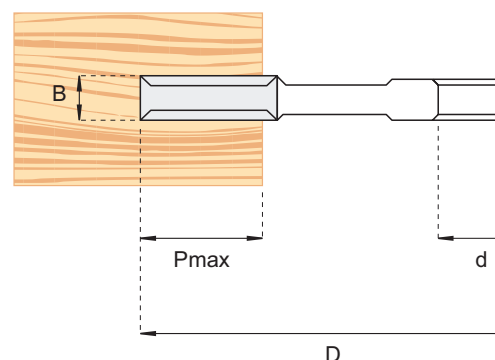

02

Fresas e porta lâminas rectos · Fresas y cabezales rectos

Porta-lâminas de ranhurar com vincadores
Cabezal para ranhurar com precortadores

2051

HW · MAN

D	B	d	Z	V	Tmax	n min · n max	Ref.
140	8	50	4	4	32	5500 - 9500	2051.201
	10	50	4	4	32	5500 - 9500	2051.202
	12	50	4	4	32	5500 - 9500	2051.203
	15	50	4	4	32	5500 - 9500	2051.204



ACESSÓRIOS - Piezas de recambio

	dim.	B	Ref.
LÂMINA	7,5x12x1,5	8	5000.01.1
	9,6x12x1,5	10	5000.04.1
	11,6x12x1,5	12	5000.06.1
	14,6x12x1,5	15	5000.08.1
CALÇO		8	5400.006
		10	5400.008
		12	5400.010
		15	5400.013
PERNO (DIN915)	M5x16	8	5105.002
	M6x16	10	5105.005
	M8x16	12/15	5105.007
VINCADOR	14x14x2		5002.01.1
PARAFUSO (DIN963)	M5x6	8/10	5107.002
	M5x8	12/15	5107.003
CHAVE EM T	SW2,5 (M5)		5302.101
	SW3 (M6)		5302.102
	SW4 (M8)		5302.103

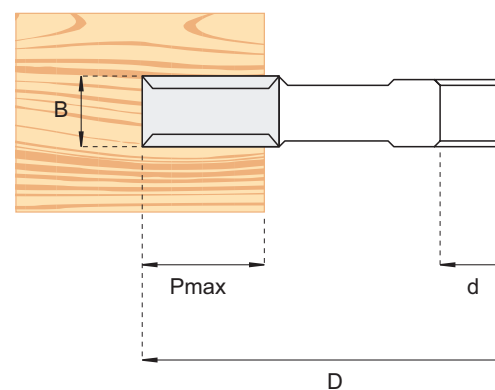

03



Fresa de ranhurar 1000

Fresa de ranhurar

02

Fresas e porta láminas rectos · Fresas y cabezales rectos



HW · MAN

D	B	d	Z	Tmax	n min · n max	Ref.
140	4	50	4	32	5500 - 9000	1000.201
	5	50	4	32	5500 - 9000	1000.202
	6	50	4	32	5500 - 9000	1000.203
	7	50	4	32	5500 - 9000	1000.204
	8	50	4	32	5500 - 9000	1000.205
	10	50	4	32	5500 - 9000	1000.206
	12	50	4	32	5500 - 9000	1000.207
	14	50	4	32	5500 - 9000	1000.208
	16	50	4	32	5500 - 9000	1000.209
	18	50	4	32	5500 - 9000	1000.210
	20	50	4	32	5500 - 9000	1000.211
	25	50	4	32	5500 - 9000	1000.212

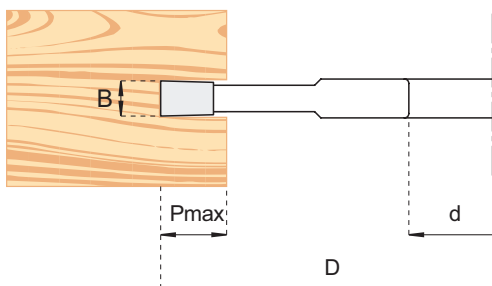

1001 Fresa de ranhurar

Fresa de ranhurar



HW · MAN

D	B	d	Z	Tmax	n min · n max	Ref.
140	4	50	6	32	5500 - 9000	1001.201
	5	50	6	32	5500 - 9000	1001.202
	6	50	6	32	5500 - 9000	1001.203
	7	50	6	32	5500 - 9000	1001.204
	8	50	6	32	5500 - 9000	1001.205
	10	50	6	32	5500 - 9000	1001.206
	12	50	6	32	5500 - 9000	1001.207
	14	50	6	32	5500 - 9000	1001.208
	16	50	6	32	5500 - 9000	1001.209
	18	50	6	32	5500 - 9000	1001.210
	20	50	6	32	5500 - 9000	1001.211

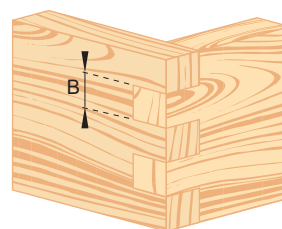
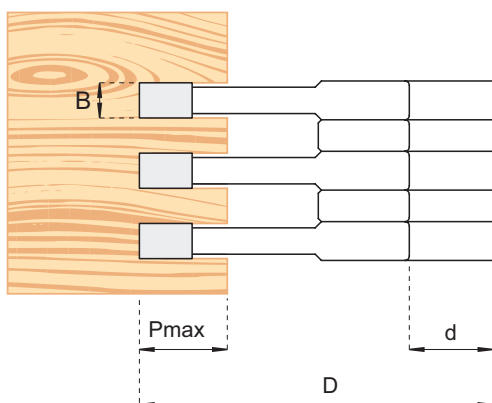

04



HW · MAN

D	B	d	Z	V	Tmax	n min · n max	Ref.
140	4	50	4	4	32	5500 - 9500	1003.201
	5	50	4	4	32	5500 - 9500	1003.202
	6	50	4	4	32	5500 - 9500	1003.203
	8	50	4	4	32	5500 - 9500	1003.204
	10	50	4	4	32	5500 - 9500	1003.205
	12	50	4	4	32	5500 - 9500	1003.206
	16	50	4	4	32	5500 - 9500	1003.207
	18	50	4	4	32	5500 - 9500	1003.208
	20	50	4	4	32	5500 - 9500	1003.209
160	4	50	4	4	42	4800 - 8300	1003.301
	6	50	4	4	42	4800 - 8300	1003.303
	8	50	4	4	42	4800 - 8300	1003.304
	10	50	4	4	42	4800 - 8300	1003.305
	12	50	4	4	42	4800 - 8300	1003.306
	16	50	4	4	42	4800 - 8300	1003.307
	20	50	4	4	42	4800 - 8300	1003.308

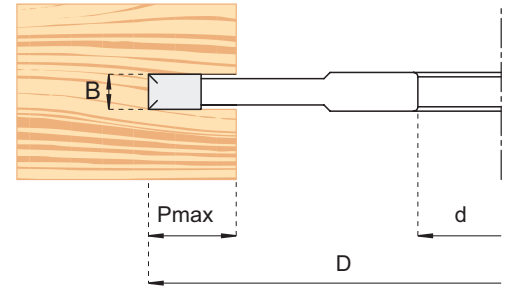

02

Fresas e porta lâminas rectos · Fresas y cabezales rectos

Fresa de ranhurar com vincadores
Fresa de ranurar con precortadores

1376

HW · MAN

D	B	b	d	Z	NL	n min · n max	Ref.
100	3.97	2.8	22	6	4/4.5/36	7800 - 13300	1376.001
100	3.97	2.8	22	8	4/4.5/36	7800 - 13300	1376.002

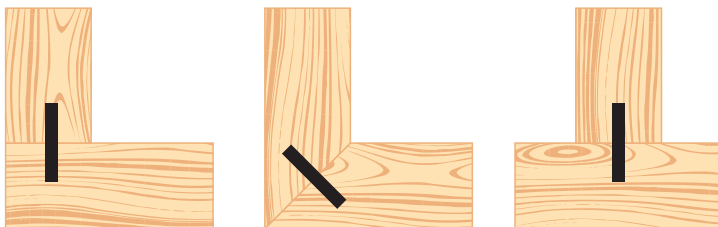



2500 Porta-lâminas de ranhurar para máquina tipo "lamello" Fresa para ranurar "lamello"



HW · MAN

D	B	d	Z	V	NL	n min - n max	Ref.
100	3,97	22	4	4	4 / 4,5 / 36	7800 - 13300	2500.001

ACESSÓRIOS - Peças de recambio

	dim.	Ref.
LÂMINA	18x18x1,95	5013.01
ANILHA DE APERTO	11,9x1,7	5111.001
VINCADOR	14x14x1,2	5002.03.1
ANILHA DE APERTO	9,9x1,6	5110.001
PARAFUSO	M4x3,2	5109.001
CHAVE TORX	T9	5302.201

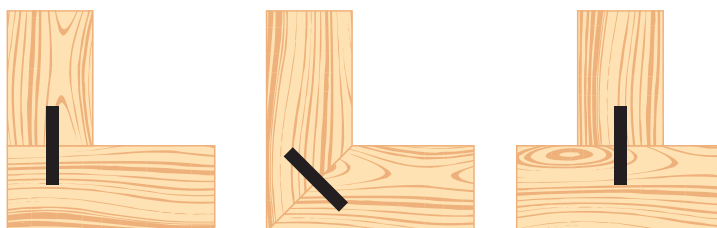

2053 Porta-lâminas extensível de ranhurar com vincadores Cabezal extensível para ranurar com precortadores

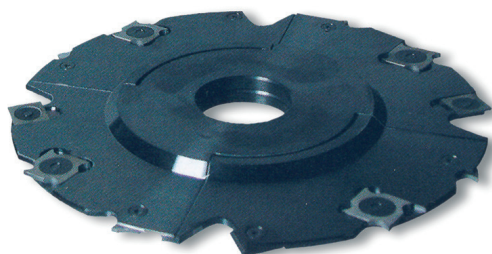

HW · MAN

D	B	d	Z	V	Tmax	n min · n max	Ref.
160	4-7,5	50	8	4	32	4800 - 8000	2053.301
	4-15	50	8	4	32	4800 - 8000	2053.302
180	4-7,5	50	8	4	38	4500 - 7000	2053.401
	4-15	50	8	4	38	4500 - 7000	2053.402

ACESSÓRIOS - Peças de recambio

	dim.	B	Ref.
LÂMINA	7,5x12x1,5	7,5	5000.01.1
CALÇO		7,5	5400.006
PERNO (DIN915)	M5x12	7,5	5105.001
LÂMINA	18x18x1,95		5013.01
ANILHA DE APERTO	11,9x1,7		5110.002
VINCADOR	14x14x1,2		5002.01.1
ANILHA DE APERTO	9,9x1,6		5110.001
PARAFUSO	M4x3,2		5109.001
CHAVE EM T	SW2,5(M5)		5302.101
CHAVE TORX	T9		5302.201
JOGO DE ANILHAS		4-7,5	5075.904

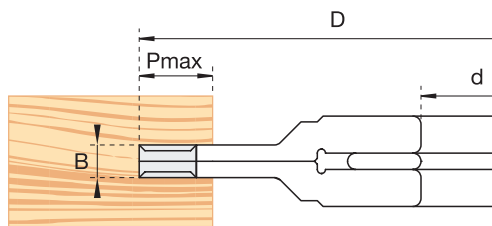



HW · MAN

D	B	d	Z	V	Tmax	n min · n max	Ref.
160	8-15	50	4	4	32	4800 - 8000	2054.301
	12,6-24	50	4	4	32	4800 - 8000	2054.302
180	10-19,5	50	4	4	32	4800 - 8000	2054.303
	8-15	50	4	4	38	4300 - 7000	2054.401
	12,6-24	50	4	4	38	4300 - 7000	2054.402

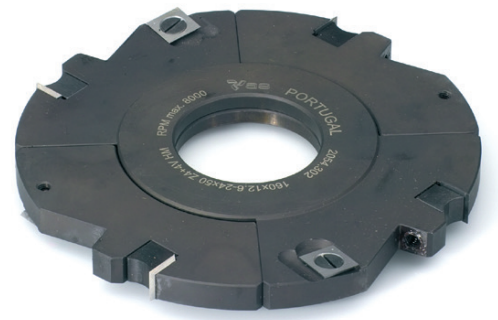

ACESSÓRIOS - Piezas de recambio

	dim.	B	Ref.
Lâmina	7,5x12x1,5	8-15	5000.01.1
	9,6x12x1,5	10-19,5	5000.04.1
	12x12x1,5	12,6-24	5003.01.1
Calço		8-15	5400.006
		10-19,5	5400.008
		12,6-24	5400.010
Perno (DIN915)	M5x16	8-15	5105.001
	M8x16	12,6-24	5105.007
Vincador	14x14x2		5002.01.1
Parafuso (DIN963)	M5x6	8-15	5107.002
	M5x8	12,6-24	5107.003
Chave em T	SW2,5 (M5)		5302.101
	SW4 (M8)		5302.103
Jogo de anilhas		8-15	5075.801
		12,6-24	5075.802
		10-19,5	5075.803

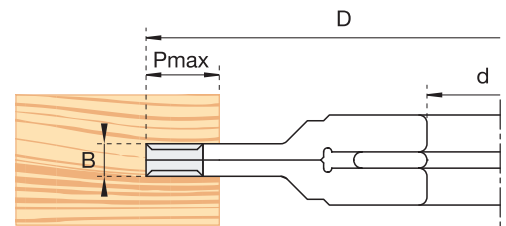



1050 Fresa extensível de ranhurar com vincadores

Fresa extensible para ranurar con precortadores

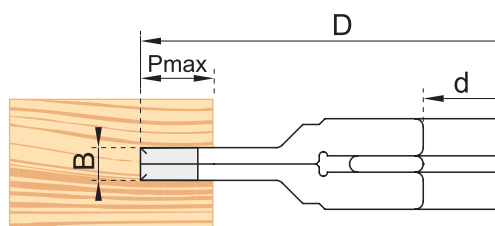

HW · MAN

D	B	d	Z	V	Tmax	n min · n max	HW Ref.
120	3,5 – 6,5	50	4	4	16	10000	1050.101
	4 – 7,5	50	4	4	16	10000	1050.102
	5 – 9,5	50	4	4	16	10000	1050.103
	7 – 13,5	50	4	4	16	10000	1050.104
140	10 – 19,5	50	4	4	16	10000	1050.105
	4 – 7,5	50	4	4	22	9000	1050.201
	5 – 9,5	50	4	4	22	9000	1050.202
	7 – 13,5	50	4	4	22	9000	1050.203
150	10 – 19,5	50	4	4	22	9000	1050.204
	15 – 29,5	50	4	4	22	9000	1050.205
	20 – 39,5	50	4	4	22	9000	1050.206
	30 – 59,5	50	4	4	22	9000	1050.207
160	4 – 7,5	50	4	4	27	8500	1050.251
	5 – 9,5	50	4	4	27	8500	1050.252
	7 – 13,5	50	4	4	27	8500	1050.253
	10 – 19,5	50	4	4	27	8500	1050.254
160	4 – 7,5	50	4	4	32	8000	1050.301
	5 – 9,5	50	4	4	32	8000	1050.302
	7 – 13,5	50	4	4	32	8000	1050.303
10 – 19,5	50	4	4	32	8000	1050.304	

JOGO DE ANILHAS - Juego de anillos

B	d	Ref.
3,5 – 6,5	50	5075.900
4 – 7,5	50	5075.901
5 – 9,5	50	5075.902
7 – 13,5	50	5075.903
10 – 19,5	50	5075.904
15 – 29,5	50	5075.905
20 – 39,5	50	5075.906
30 – 59,5	50	5075.907

1051 Fresa extensível de ranhurar com vincadores

Fresa extensible para ranurar con precortadores

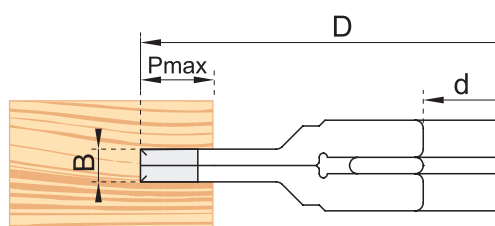

HW · MAN

D	B	d	Z	V	Tmax	n max	HW Ref.
200	5 – 9,5	30/50	4	4	45	6000	1051.501
	7 – 13,5	30/50	4	4	45	6000	1051.502
	10 – 19,5	30/50	4	4	45	6000	1051.503
250	7 – 13,5	30/50	4	4	70	5000	1051.751
	10 – 19,5	30/50	4	4	70	5000	1051.752
	15 – 29,5	30/50	4	4	70	5000	1051.753

JOGO DE ANILHAS - Juego de anillos

B	d	Ref.
5 – 9,5	30/50	5075.902
7 – 13,5	30/50	5075.903
10 – 19,5	30/50	5075.904
15 – 29,5	30/50	5075.905



HW · MAN

D	B	d	Z	V	Tmax	n min · n max	HW Ref.
200	7 – 13,5	30	8	8	35	3900 - 6000	1052.501
	10 – 19,5	30	8	8	35	3900 - 6000	1052.502
	15 – 29,5	30	8	8	35	3900 - 6000	1052.503
250	7 – 13,5	30	8	8	40	3100 - 5000	1052.751
	10 – 19,5	30	8	8	40	3100 - 5000	1052.752
	15 – 29,5	30	8	8	40	3100 - 5000	1052.753



JOGO DE ANILHAS - Juego de anillos

B	Ref.
7 – 13,5	5075.903
10 – 19,5	5075.904
15 – 29,5	5075.905

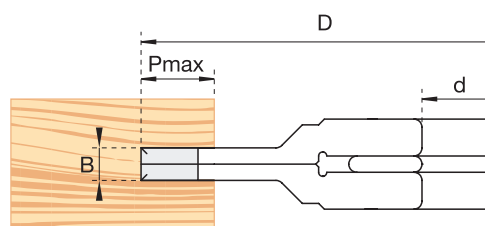

Porta-lâminas extensível para ranhurar e rebaixar com vincadores
Cabezal extensible para galces con precortadores

HW · MAN

D	B	d	Z	V	n min · n max	Ref.
160	16-30	50	4	4	4700 - 8000	2055.301
	21-40	50	4	4	4700 - 8000	2055.302
	31-60	50	4	4	4700 - 8000	2055.303
	51-100	50	4	4	4700 - 8000	2055.304



ACESSÓRIOS - Piezas de recambio

	dim.	B	Ref.
Lâmina	15x12x1,5	16-30	5000.09.1
	20x12x1,5	21-40	5000.12.1
	30x12x1,5	31-60	5000.13.2
	50x12x1,5	51-100	5001.07.1
Calço		16-30	5401.015
		21-40	5401.020
		31-60	5401.030
		51-100	5401.050
Perno (DIN915)	M8x16		5105.007
Vincador	14x14x2		5002.01.1
Parafuso (DIN963)	M5x8		5107.003
Chave em T	SW4		5302.103
Jogo de Anilhas		16-30	5075.906
		21-40	5075.907
		31-60	5075.908
		51-100	5075.910

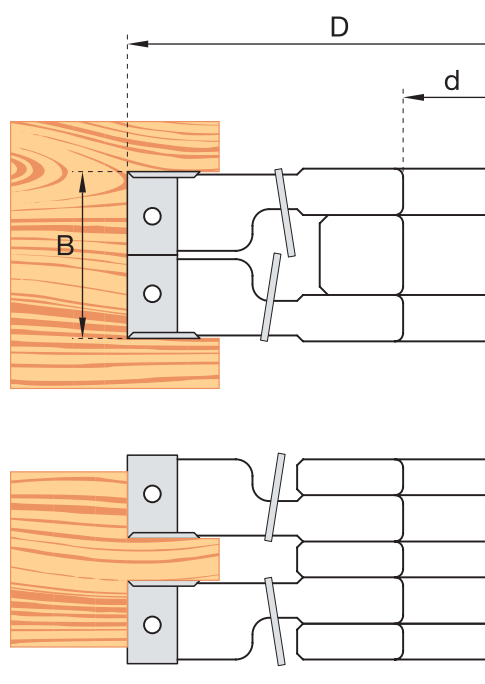



2076 Porta-lâminas para facejar Cabezal para cepillar

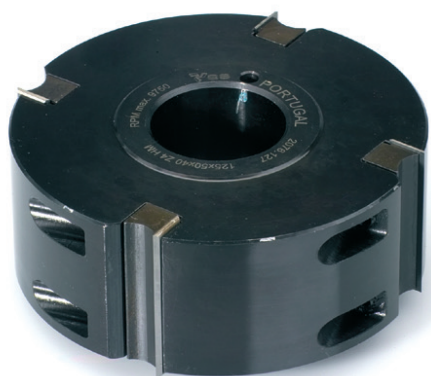

HW · MAN

D	B	d	Z	n min · n max	Ref.
100	30	30	4	7800 - 13400	2076.002
	50	30	4	7800 - 13400	2076.003
125	30	40/50	4	6200 - 10800	2076.125
	*	30	40	6200 - 10800	2076.126
*	50	40/50	4	6200 - 10800	2076.127
	*	50	40	6200 - 10800	2076.128

ACESSÓRIOS - Piezas de recambio

	dim.	B	Ref.
Lâmina	30x12x1,5	30	5001.01.1
	50x12x1,5	50	5001.07.1
Calço		30	5400.028
		50	5400.048
Perno (DIN915)	M8x16		5105.007
Chave em T	SW4 (M8)		5302.103

* CORPO EM LIGA LEVE - Cuerpo de aleación ligera

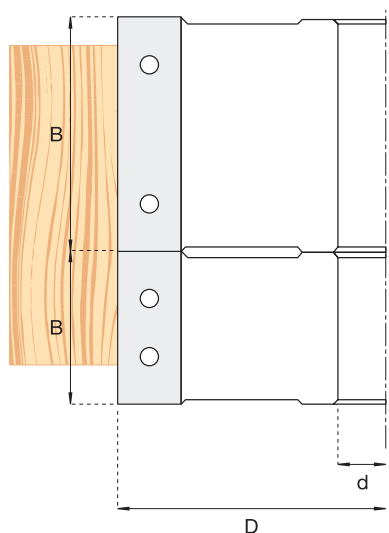

2077 Porta-lâminas para galgar painéis Cabezal para cantear



HW · MAN

D	B	d	Z	n max	Ref.
125	56	30/40 DKN	3+3	10000	2077.125
150	56	30/40 DKN	3+3	8500	2077.250
180	56	30/40 DKN	3+3	7000	2077.400

ACESSÓRIOS - Piezas de recambio

	dim.	B	Ref.
Lâmina	30x12x1,5	30	5001.01.1
Calço		RH	C2077.01
		LH	C2077.02
Perno (DIN915)	M8x16		5105.007
Chave em T	SW4		5302.103

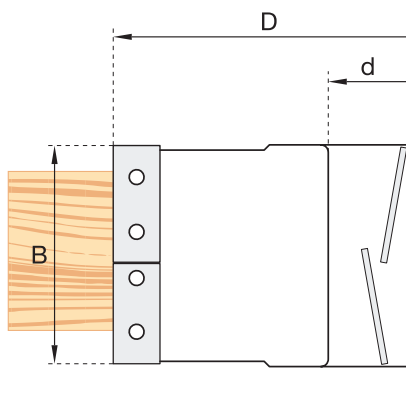



HW · MAN

D	B	d	Z	V	n min · n max	Ref.
100	50	40	4	4	7800 - 12000	2078.002
125	30	50	4	4	6200 - 10000	2078.126
	50	50	4	4	6200 - 10000	2078.128
	60	50	4	4	6200 - 10000	2078.129



ACESSÓRIOS - Piezas de recambio

	dim.	B	Ref.
Lâmina	30x12x1,5	30	5001.01.1
	50x12x1,5	50	5001.07.1
	60x12x1,5	60	5001.11.1
Calço		30	5400.028
		50	5400.048
		60	5400.058
Perno (DIN915)	M8x16		5105.007
Vincador	14x14x2		5002.01.1
Parafuso (DIN963)	M5x8		5107.033
Chave em T	SW4		5302.103

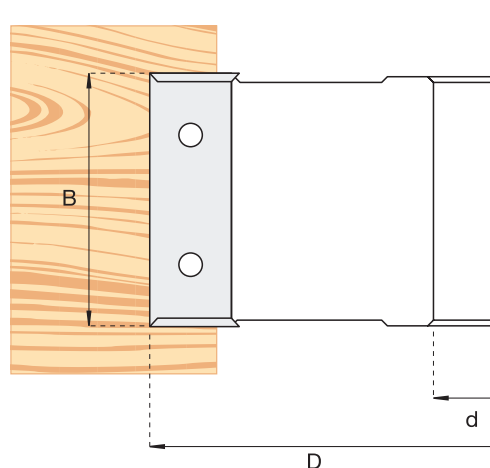

02

Fresas e porta lâminas rectos · Fresas y cabezales rectos

Porta-lâminas para facejar e rebaixar Axial com vincadores
Cabezal para galces con precortadores

HW · MAN

D	B	d	Z	V	n min · n max	Ref.
125	50	30/50	4	4	6200 - 10000	2079.125
140	50	30/50	4	4	5500 - 9000	2079.201
	30	30/50	4	4	5500 - 9000	2079.203
147	50	30/50	4	4	5200 - 8500	2079.202



ACESSÓRIOS - Piezas de recambio

	dim.	B	Ref.
Lâmina	50x12x1,5	50	5001.07.1
Calço	RH		5403.048
	LH		5404.048
Perno (DIN915)	M8x16		5105.007
Vincador	14x14x2		5002.01.1
Parafuso (DIN963)	M5x8		705.422
Chave em T	SW4		5302.103

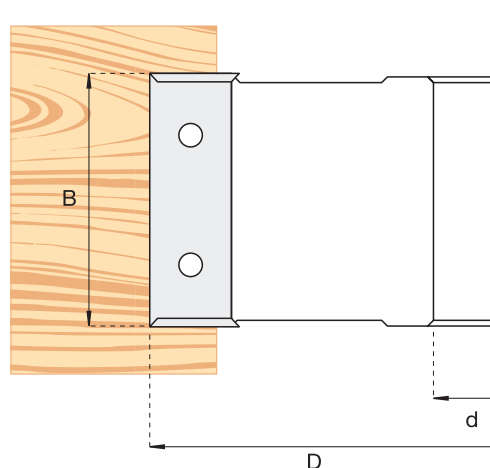



1100 Fresa de rebaixar com vincadores

Fresa para galces con precortadores



HW · MAN

D	B	d	Z	V	n min · n max	Ref.
140	30	50	4	4	5500 - 9000	1100.201
	40	50	4	4	5500 - 9000	1100.202
	50	50	4	4	5500 - 9000	1100.203

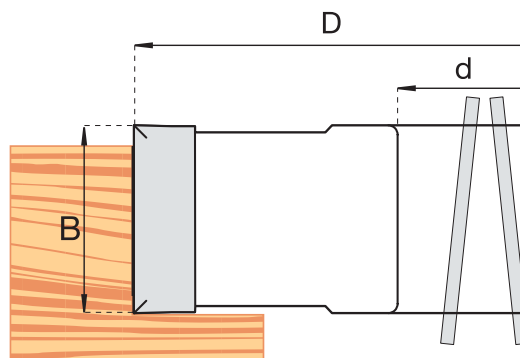

2000 Porta - lâminas de guia com vincadores

Cabezal para guia con precortadores



HW · MEC

D	B	d	Z	V	n max	HW Ref.
145	12	40	3	3	9000	2000.141

ACESSÓRIOS - Piezas de recambio

	dim.	B	Ref.
Lâmina	12x12x1,5	12	5003.01.1
Calço			5400.010
Perno (DIN915)	M8x16		5105.007
Vincador	14x14x2		5002.01.1
Parafuso (DIN963)	M5x8		5107.003
Chave em T	SW4		5302.103

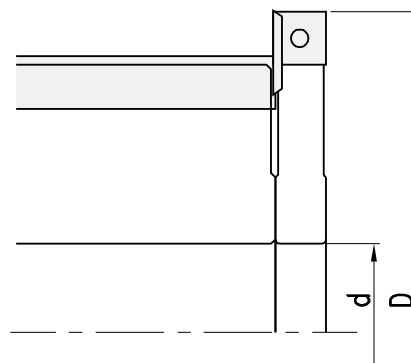
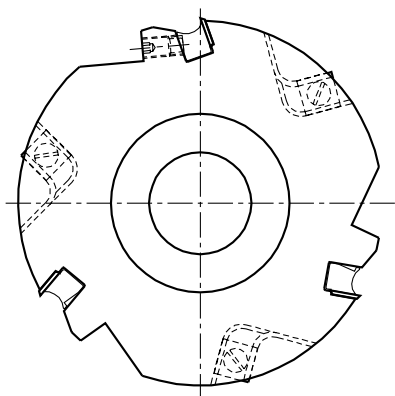



HW · MEC

D	B	d	Z	n min · n max	Ref.	Ref.
125	80	40	4	9000	* 2080.001	2080.125
	100	40	4	9000	* 2080.002	2080.126
	120	40	4	9000	* 2080.003	2080.127
	130	40	4	9000	* 2080.004	2080.128
	150	40	4	9000	* 2080.005	2080.129
	180	40	4	9000	* 2080.006	2080.130
	220	40	4	9000	* 2080.007	2080.131
	230	40	4	9000	* 2080.008	2080.132

* CORPO EM LIGA LEVE - Cuerpo de aleación ligera

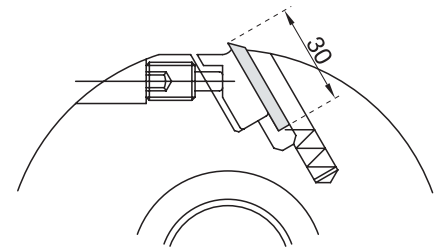
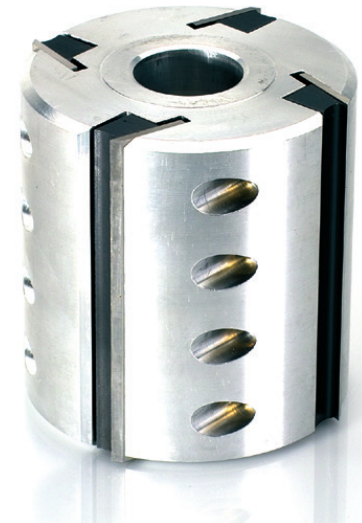

ACESSÓRIOS - Piezas de recambio

	dim.	B	Ref.
Calço		80	5405.080
		100	5405.100
		120	5405.120
		130	5405.130
		150	5405.150
		180	5405.180
		220	5405.220
	230	5405.230	
Mola			5091.001
Perno (DIN915)	M10x20		5105.011
Chave em T	SW5		5302.104

LÂMINAS - Cuchillas

B	H	S	HS (18%W)	HW Ref.
80	30	3	5050.080.30	5051.080.30
100	30	3	5050.100.30	5051.100.30
120	30	3	5050.120.30	5051.120.30
130	30	3	5050.130.30	5051.130.30
150	30	3	5050.150.30	5051.150.30
170	30	3	5050.170.30	5051.170.30
180	30	3	5050.180.30	5051.180.30
200	30	3	5050.200.30	5051.200.30
220	30	3	5050.220.30	5051.220.30
230	30	3	5050.230.30	5051.230.30

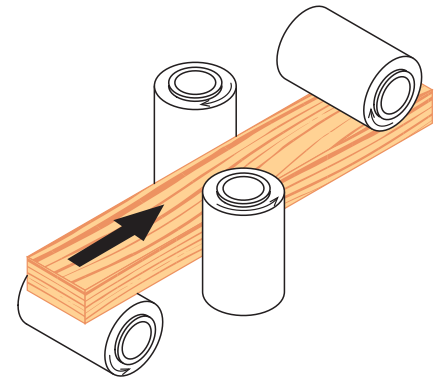



2150 Porta-lâminas para facejar Cabezal para cepillar



HW · MEC

D	B	d	Z	n min · n max	Ref.
125	88	40	(3)15	11000	* 2150.125
	119	40	(3)21	11000	* 2150.126
	139	40	(3)24	11000	* 2150.127
	156	40	(3)27	11000	* 2150.128
	173	40	(3)30	11000	* 2150.129
	218	40	(3)39	11000	* 2150.130
	234.5	40	(3)42	11000	* 2150.131

* CORPO EM LIGA LEVE - Cuerpo de aleación ligera

ACESSÓRIOS - Piezas de recambio

	dim.	Ref.
Lâmina	20x12x1,5	5005.01
Calço		5419.020
Perno (DIN915)	M8x12	5105.006
Chave em T	SW4	5302.103

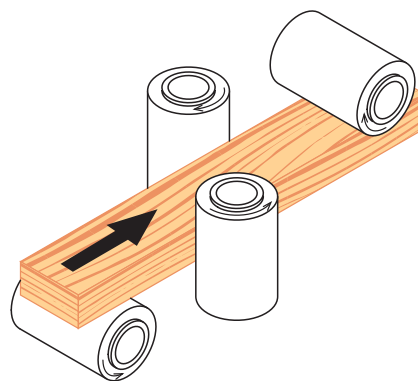
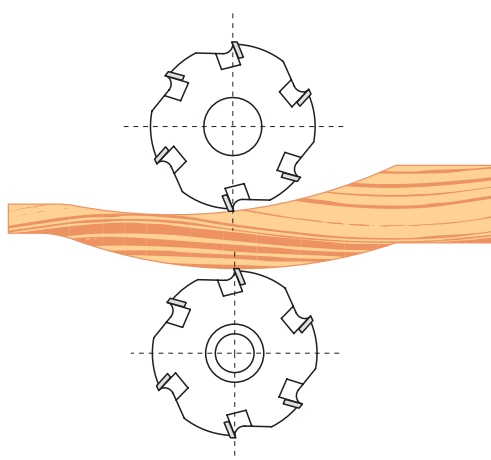

02

Fresas e porta lâminas rectos · Fresas y cabezales rectos



HW · MEC

D	B	d	Z	n min · n max	Ref.
125	100	40	3(30)	10000	* 2550.125
	130	40	3(36)	10000	* 2550.126
	180	40	3(48)	10000	* 2550.127
	230	40	3(60)	10000	* 2550.128

* CORPO EM LIGA LEVE - Cuerpo de aleación ligera

ACESSÓRIOS - Piezas de recambio

dim.	Ref.
Lâmina 15x15x2,5	5002.04.1
Parafuso M5x14	5108.002

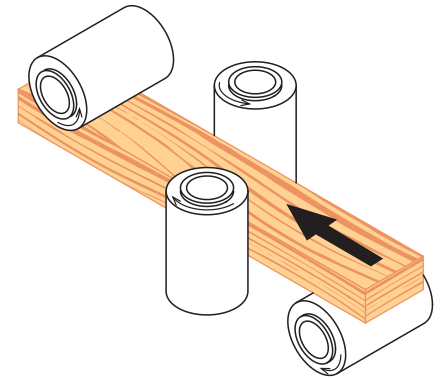

02

Fresas e porta lâminas rectos · Fresas y cabezales rectos

Fresa helicoidal para facejar
Fresa helicoidal para cepillar

1325

HW · MEC

D	B	d	Z	n max	HW Ref.
100	120	35	8	11000	1325.001
100	180	35	8	11000	1325.002
125	80	40	12	9000	1325.125
125	100	40	12	9000	1325.126
125	120	40	12	9000	1325.127
125	130	40	12	9000	1325.128
125	150	40	12	9000	1325.129
125	180	40	12	9000	1325.130
125	190	40	12	9000	1325.131
125	230	40	12	9000	1325.132





2200 Porta – lâminas para afagar orlas Cabezal para encoladora de cantos

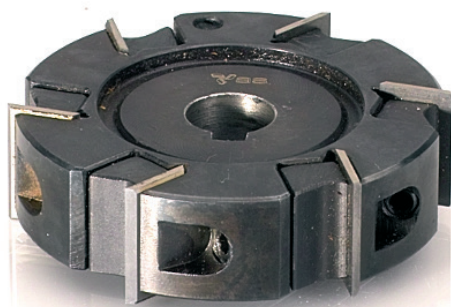

HW · MEC

D	B/d	d	DKN	Z	n max	Máquina	Ref.
50	12/10	16	5x2,3	2	18000	Homag – Homburg	2200.001
50	15/10	16	5x2,3	2	18000	IMA – Raimann	2200.002
70	12/10	16	5x2,3	4	18000	Brandt – Homag	2200.003
70	12/10	16	5x2,3	6	18000	Brandt – Homag	2200.004
70	20/14	12		6	18000	Stefani	2200.005
80	20/10	14	5x2,5	4	18000	Stefani	2200.006
70	20/20	16	5x2,3	4	18000	Ott	2200.007
70	20/11	16	5x2,3	4	18000	Homag – Homburg	2200.008
70	20/10	16		6	18000	Olimpic	2200.009
70	30/12	16		4	18000	Olimpic	2200.010
70	40/20	16		4	18000	Olimpic	2200.011
70	20/11	16	5x2,3	6	18000	Homag	2200.012
70	20/11	20	6x3,5	4	18000	Holz-Her	2200.013
80	40/25	30	8x3,3	4	18000	Holz-Her	2200.014

D	B/d	d	DKN	Z	n max	Máquina	Ref. Esq	Ref. Drt
70	20/12,5	16	5x2,3	4	18000	Homag	2200.015	2200.016
70	20/12,5	20	6x3,5	4	18000	Brandt - Homag - IMA - IDM	2200.017	2200.018
70	20/12,5	20	6x3,5	6	18000	Brandt - Homag - IMA - IDM	2200.019	2200.020

ACESSÓRIOS - Peças de recambio

	dim.	B	Ref.
Lâmina	12x12x1,5		5003.01.1
	15x12x1,5		5000.09.1
	20x12x1,5		5000.12.1
	30x12x1,5		5001.01.1
	40x12x1,5		5001.05.1
Calço		12	5402.010
		15	5402.013
		20	5402.018
		30	5402.028
		40	5402.038
Perno (DIN915)	M6x12		5105.004
Chave em T	SW3		5302.007

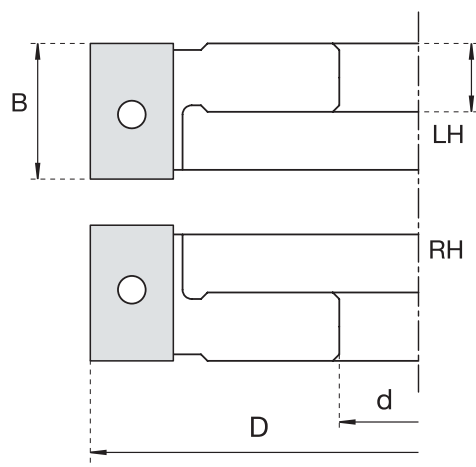
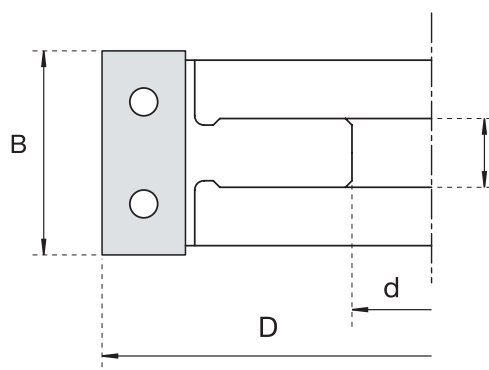

02

Fresas e porta lâminas rectos · Fresas y cabezales rectos



HW · MEC

D	B/d	d	Z	n max	Ref. Esq	Ref. Drt
Homag - IMA						
70	14,3/23	HSK25R	4	18000	2201.001	2201.002

ACESSÓRIOS - Piezas de recambio

dim.	Ref.	
Lâmina	14,3x14,3x2,5	5003.05.1
Parafuso	M5x13	
Chave Torx	T20	5302.205

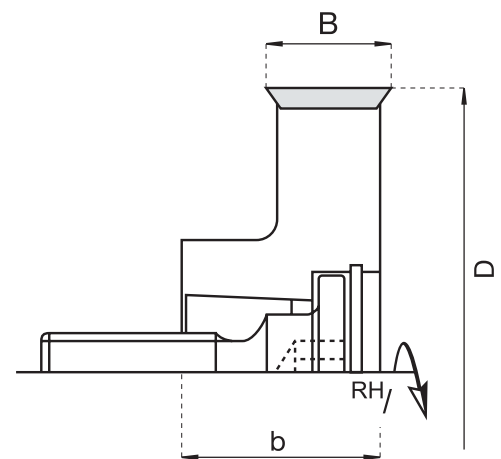

02

Fresas e porta lâminas rectos · Fresas y cabezales rectos

Porta-lâminas para afagar orlas
Cabezal para encoladora de cantos

2202

HW · MEC

D	B/d	d	Z	n max	Ref. Esq	Ref. Drt
Homag - IMA						
70	24	HSK25R	4	18000	2202.001	2202.002

ACESSÓRIOS - Piezas de recambio

dim.	Ref.	
Lâmina	24,7x12x1,5	5000.16.1
Calço		
Parafuso	M8x12	5105.006
Chave Torx	SW4	5302.103

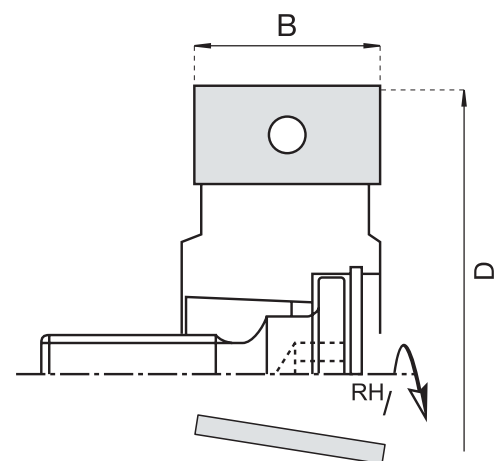

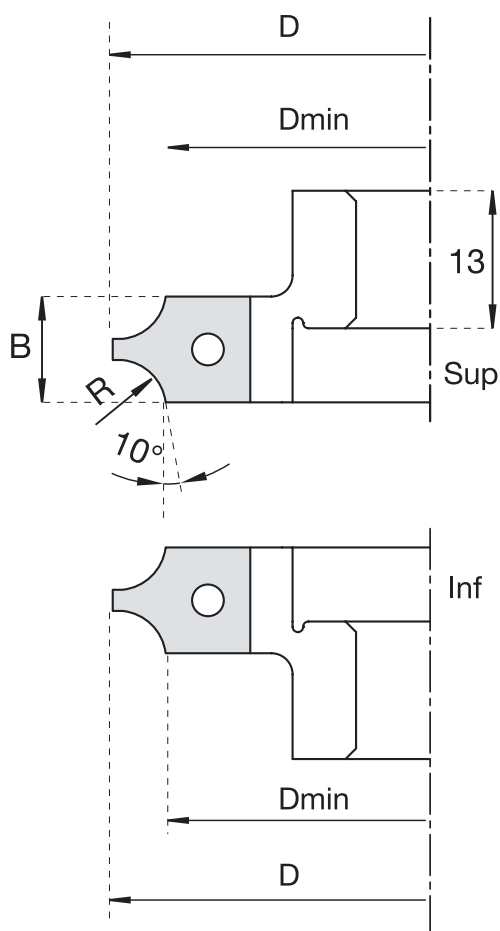
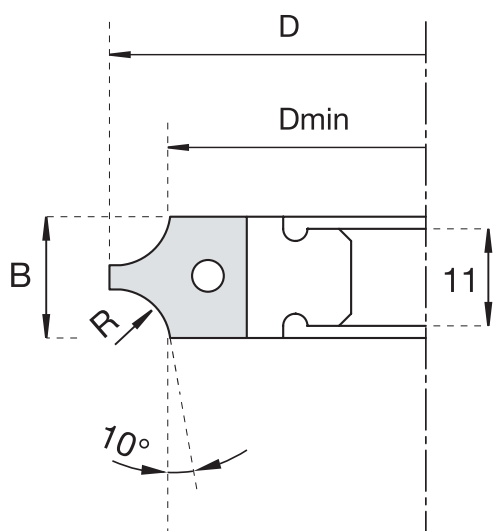
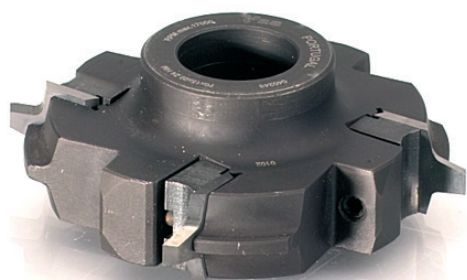

HW · MEC

D	B	d	Dmin	DKN	R	Z	n max	Máquina	Ref.
73	16	16	61	5x2,3	2	3	18000	Homag	2203.001
73	16	16	61	5x2,3	3	3	18000	Homag	2203.002
73	16	16	61	5x2,3	4	3	18000	Homag	2203.003
73	16	16	61	5x2,3	5	3	18000	Homag	2203.004
73	16	20	61	6x3,5	2	3	18000	HolzHer	2203.005
73	16	20	61	6x3,5	3	3	18000	HolzHer	2203.006
73	16	20	61	6x3,5	4	3	18000	HolzHer	2203.007
73	16	20	61	6x3,5	5	3	18000	HolzHer	2203.008
82	16	20	70	6x3,5	2	4	18000	IMA – Wilmsmeyer	2203.009
82	16	20	70	6x3,5	3	4	18000	IMA – Wilmsmeyer	2203.010
82	16	20	70	6x3,5	4	4	18000	IMA – Wilmsmeyer	2203.011
82	16	20	70	6x3,5	4	4	18000	IMA – Wilmsmeyer	2203.012

D	B	d	Dmin	DKN	R	Z	n max	Máquina	Ref. HW
82	16	20	70	6x3,5	2	4	18000	IMA	2203.013
82	16	20	70	6x3,5	2	4	18000	IMA	2203.014
82	16	20	70	6x3,5	3	4	18000	IMA	2203.015
82	16	20	70	6x3,5	3	4	18000	IMA	2203.016
82	16	20	70	6x3,5	4	4	18000	IMA	2203.017
82	16	20	70	6x3,5	4	4	18000	IMA	2203.018
82	16	20	70	6x3,5	5	4	18000	IMA	2203.019
82	16	20	70	6x3,5	5	4	18000	IMA	2203.020

ACESSÓRIOS - Peças de recambio

dim.	Ref.
Lâmina	16x17,5x2 R2 5025.01
	16x17,5x2 R3 5025.02
	16x17,5x2 R4 5025.03
	16x17,5x2 R5 5025.04
Calço	5406.014
Perno (DIN915)	M6x12 5105.004
Chave em T	SW3 5302.102



HW · MAN

D	B	d	Z	C	n max	HW Ref.
125	50	40/50	4	4	10600	2228.125

ACESSÓRIOS - Piezas de recambio

	dim.	Ref.
Lâmina	50x12x1,5	5001.07.1
Calço		C2228.01
Perno (DIN915)	M8x16	5105.007
Chanfrador 45°		5027.01
Boleador	R=2	5027.02
	R=3	5027.03
Parafuso - Tornillo	M5x13,5	5108.001
Perno - Tornillo (DIN915)	M5x12	5105.001



02

Fresas e porta lâminas rectos · Fresas y cabezales rectos

araújo&silva
ferramentas de corte

www.araujosilva.pt